

MODEL NUMBER	IXHHI1.5-12-182T		
HORSEPOWER	1.5		
RPM / POLES	1200 / 6		
VOLTAGE / PHASE	230 / 460 V / 3		
FRAME	182T		
ENCLOSURE / DEGREE OF PROTECTION	TEFC / IP54		
FREQUENCY	60 HZ		
FULL LOAD SPEED	1160 RPM		
SERVICE FACTOR	1.15		
INSULATION CLASS	F Class N Varnish		
FULL LOAD AMPS; 230 / 460	4.6 / 2.3 A Usable On 208 V At 5.1 A		
LOCKED ROTOR CURRENT (% Full Load)	850 / 850 %		
NEMA CODE LETTER	L		
EFFICIENCY / POWER FACTOR	<u>LOAD</u>	<u>EFF.</u>	<u>P.F.</u>
	100 %	87.5 %	68.0 %
	75 %	87.7 %	60.0 %
	50 %	84.0 %	48.0 %
DUTY CYCLE	S1 / Continuous		
TORQUE	<u>FULL LOAD</u>	<u>LRT</u>	<u>BDT</u>
	6.7 lb.ft.	190 %	270 %
NEMA DESIGN	B		
MOMENT OF INERTIA	<u>LOAD (Max.)</u>	<u>MOTOR</u>	
	69.175 lb.ft. ²	0.593 lb.ft. ²	
SOUND PRESSURE LEVEL (No Load 1 M From Motor)	60 dB(A)		
MAX. SHAFT VIBRATION	0.08 In/Sec – Peak Velocity		
NUMBER OF STARTS (Hot / Cold)	2 Hot / 3 Cold		
MAX. ELEVATION	3300 Ft. Above Sea Level		
TEMPERATURE RISE (At Full Load)	80° C		
DRIVE-END BEARING	6206ZZC3		
OPPOSITE DRIVE-END BEARING	6206ZZC3		
GREASE TYPE	Mobil Polyrex EM		
MOUNTING	F1, W6, W8, B3, V5, V6		
ROTATION	Bi-Directional		
APPROXIMATE WEIGHT	112 lbs.		
AREA CLASSIFICATION	Class I, Division 1, Groups C and D		
TEMPERATURE CODE WITH THERMOSTAT USE	T4		
TEMPERATURE CODE AT 40°C AMBIENT	T2C		
TEMPERATURE CODE AT 55°C AMBIENT	T2B		
THERMOSTAT TYPE	Normally Closed		
INVERTER RATING	6:1 CT (Constant) / 10:1 CT (Intermittent-1 Hour) / 10:1 VT		
INSULATION TYPE	Hyundai Inverter Shield, Meets NEMA MG1 Part 31		
UL CERTIFICATION NUMBER	E216236		



CC 038A





TEFC

THREE PHASE INDUCTION MOTOR

TYPE

XKP,XIP

CAST IRON FRAME

FRAME SIZE

OUTPUT(HP)

POLES

Hz

TIME RATING

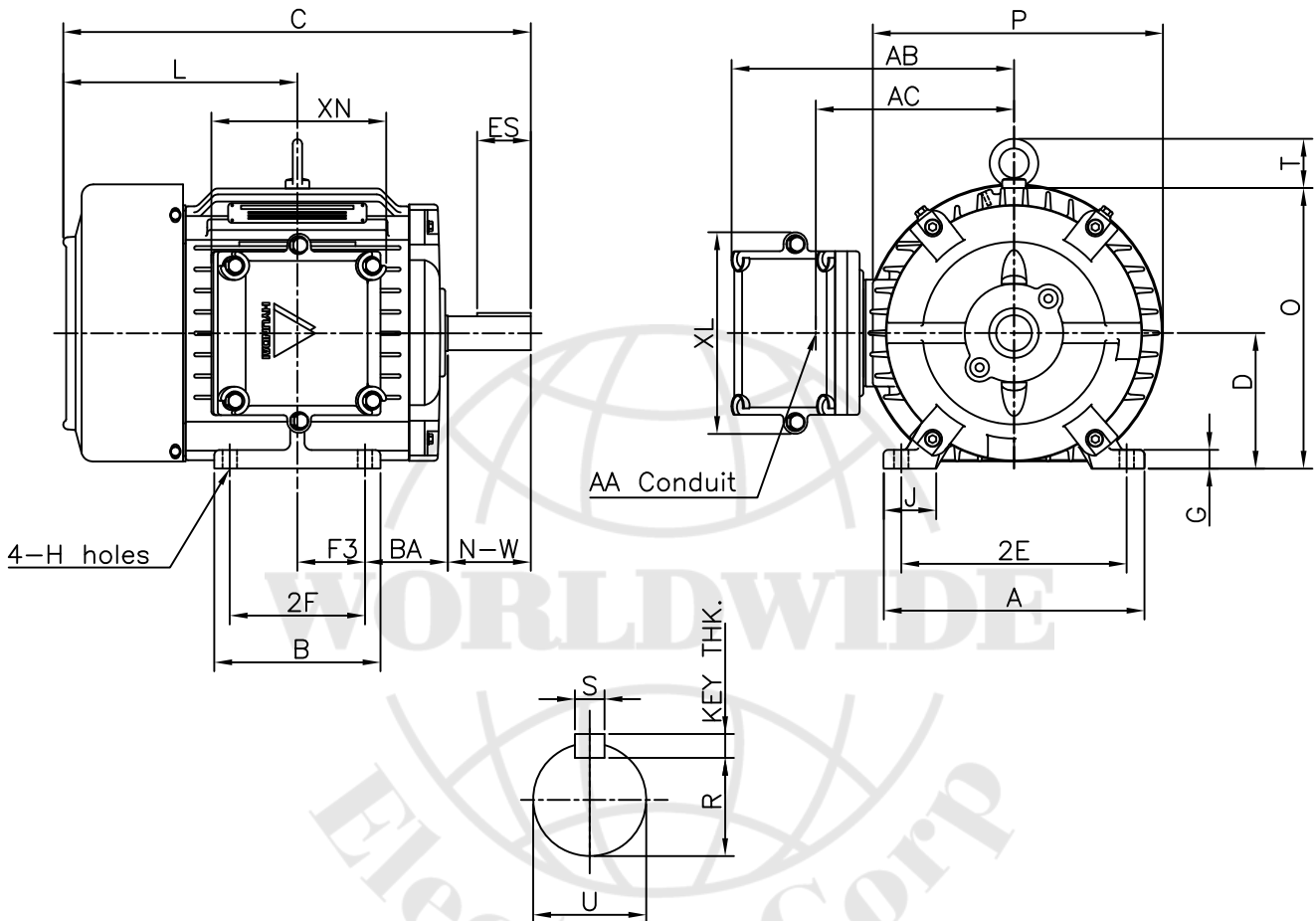

MOUNTING

CONDUIT BOX

APPROX. WGT.(lb)

A	B	2E	2F	-	F3	G	J	H	AA	AB	AC	XB	XL	XN	APPROX. WGT.(lb)
8.66	5.52	7.50	4.50	-	2.25	0.62	1.74	0.41	0.75	9.38	6.58	-	6.69	5.98	112

OVERALL

SHAFT

KEY THK.

BEARING

BA	C	D	L	O	P	T	U	N-W	KEYWAY			KEY THK.	DRIVE END	OPP. DRIVE END
									R	ES	S			
2.75	15.52	4.50	7.78	9.32	9.64	1.63	1.125	2.75	0.986	1.78	0.250	0.250	6206ZZC3	6206ZZC3

NOTE

- 1.Dimension "D" tolerance : +0.00inch - 0.03inch
- 2.Dimension "U" tolerance : +0.000inch - 0.0005inch
- 3.Dimension "R" tolerance : +0.000inch - 0.015inch

APPD BY	J.H.KIM	UNIT	INCH	SUBJECT	NEMA 182T	CAD PROJ \ FILE	LM-U1182B3TL001
CHKD BY	N.D.LEE	SCALE	1/8				
CHKD BY	K.S.LEE	PROJEC'N	3rd Angle	TITLE			
DSND BY	S.W.SEO	DATE	2012.02.11				

OUTLINE



REF. NO	LM-U1182B3TL001	Sheet No.	of
DWG NO	LM-U1182B3TL001	Revision No.	0